



**MODEL HRFG-E**



This fountain is certified to NSF/ANSI 61.

**GENERAL**

Wall-mount fountain made of Marblyte™ solid-surface non-porous polymer. Contour-formed basin with softly rounded corners and edges reduces splatter, insures proper drainage and prevents standing waste water. Designed to be easily accessible on either side to both physically challenged and able-bodied individuals. Ideally suited for installation in public areas. Model meets state and federal requirements as defined by the Americans with Disabilities Act.

**BUBBLER**

**Exclusive** one-piece, chrome plated, two-stream mound-building bubbler with non-removable anti-squirt feature and integral hood insures a satisfying drink of water.

**PUSHBUTTON ACTUATION MECHANISM**

Self-closing, vandal-resistant pushbutton does not require grasping or twisting.

**AUTOMATIC STREAM HEIGHT REGULATOR**

Self-closing assembly is located inside unit to prevent tampering. Unit resists corrosion and liming. A constant stream height is automatically maintained under line pressures that vary from 20 to 105 psi.

**BOTTOM COVER**

Fountain is equipped with a bottom cover. Cover is secured to the fountain with vandal-resistant fasteners.

**INLET STRAINER**

Easily cleaned in-line strainer screen traps particles of 140 microns or larger before they enter the waterway.

**WATER INLET**

3/8" O.D. Tubing

**DRAIN OUTLET**

1-1/4" tube outlet for 1-1/4" slip joint connection.

**SUGGESTED SPECIFICATIONS**

Fountain shall include pushbutton on the front, contour-formed basin to eliminate splashing and standing water, and shall have rounded corners and edges. Projector shall be chrome-plated vandal-resistant type with integral hood guard and anti-squirt feature. Fountain shall comply with ANSI 117:1 and ADA for visual and motion disabilities. The manufacturer shall certify the unit to meet the requirements of NSF/ANSI 61, and the Safe Drinking Water Act.

Note: Continued product improvement makes specifications subject to change without notice. See Halsey Taylor website for most current spec sheet.

**Barrier-Free Fountain**



Available in Galaxy Gray or Black Onyx Marblyte™ finish

Optional Accessories (extra cost)

Water Filter

Each HRFG-E consists of 1 carton of the following:

Fountain, Panel and Misc. Parts

Service stop not included.

Shipping weight: 35 lbs.

JOB NAME: \_\_\_\_\_  
 \_\_\_\_\_  
 \_\_\_\_\_  
 ENGINEER/CONTRACTOR NAME:  
 \_\_\_\_\_  
 APPROVAL: \_\_\_\_\_  
 DATE: \_\_\_\_\_



# HRFG-E

## Contour™ Barrier-Free Single Fountain

(CONTINUED)

NOTE: A service stop (not included) must be installed at the fountain inlet line.

NOTE: For wall support required locations see installation instructions provided with panel and fountains.

### MOUNTING INSTRUCTIONS

Refer to diagrams for rough-in of plumbing Bolt fountain securely to wall per installation instructions. Water service line and waste line are to be assembled as required. Final check for leaks and correct functions of fountain should be made. (For details see the installation instructions.)

**CAUTION — Fountain must be securely bolted to wall.**

### OPERATING PRESSURES:

Supply water 20 - 105 psi maximum

## FRONT AND SIDE VIEW

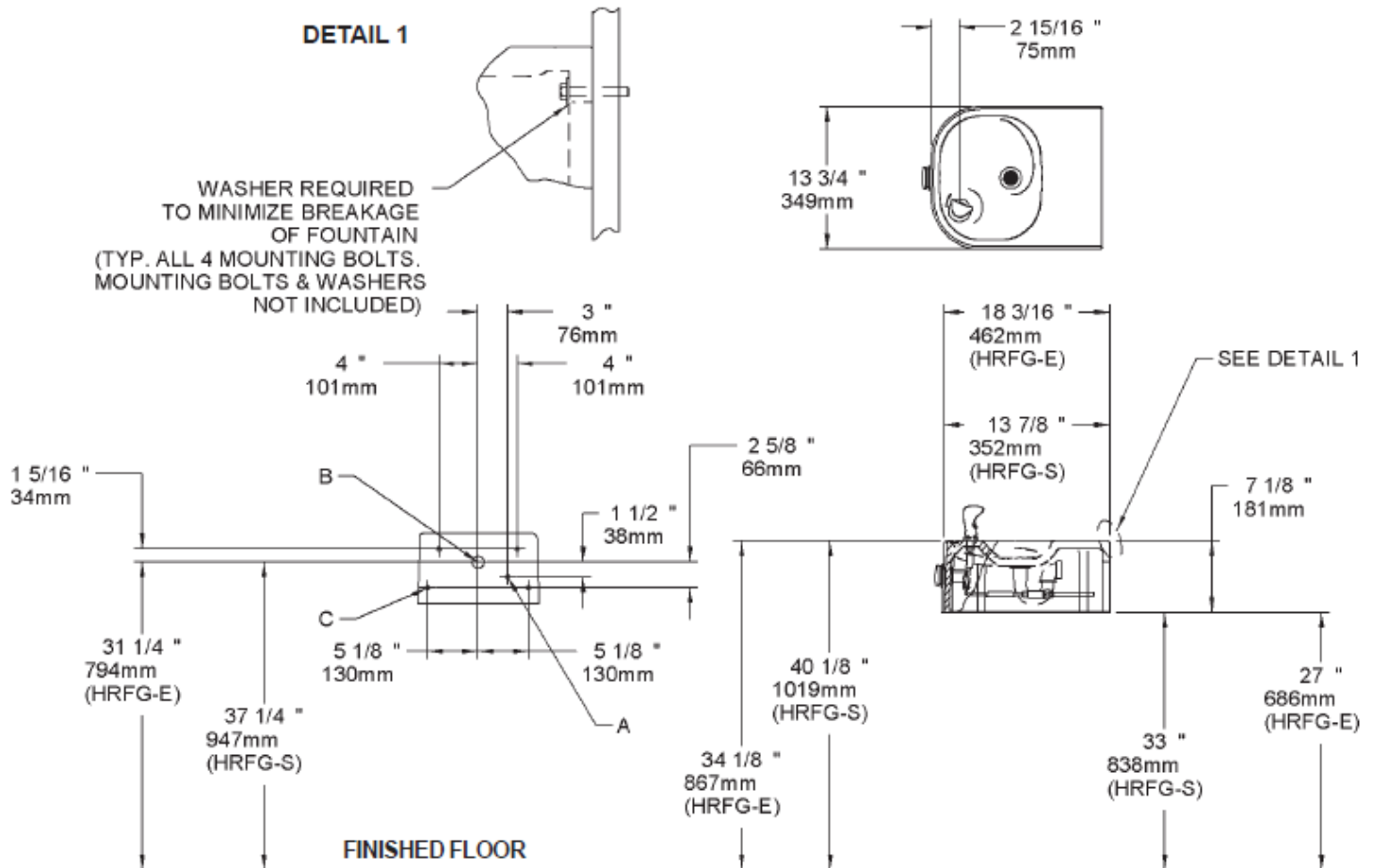

### LEGEND

- A = RECOMMENDED WATER SUPPLY LOCATION 3/8 O.D. UNPLATED COPPER TUBE CONNECT
- B = RECOMMENDED LOCATION FOR WASTE OUTLET 1-1/4" O.D. DRAIN
- C = MOUNTING HOLES FOR SECURING FOUNTAIN TO WALL